

# TechBook



in.yj™

small package, zero compromise

Full-size heater  
Field convertible 240 V to 120 V  
Quick connectors





---

## Table of contents

Warnings.....	2
Introduction .....	3
Features.....	4
Overview .....	5
- in.yj dimensions .....	5
- heat.wav dimensions .....	5
Installation .....	6
- in.yj positioning .....	6
- in.yj installation procedure with standard wall mounting bracket(s) .....	6
- in.yj installation procedure with wall mounting Z-bracket(s) .....	7
- heat.wav installation (not applicable on in.yj-re models) .....	7
- Keypad installation .....	7
Connections.....	8
- Preparation .....	8
- Connecting the main keypad and the light socket cable .....	8
- Connecting the heat.wav (not applicable on in.yj-re models) .....	9
- Connecting high voltage accessories: North American model in.yj .....	10
- Connecting high voltage accessories: European, Australian, New Zealand model in.yj-ce .....	11
- Connecting the probe assembly on heat recovery model in.yj-re .....	12
- Connecting high voltage accessories: North American heat recovery model in.yj-re .....	13
- Completing the installation .....	14
Electrical wiring .....	15
- Electrical wiring: all models .....	15
- Electrical wiring: North American models .....	15
- Electrical wiring: CE/AUS/NZS models .....	17
Power-up & breaker setting .....	18
Programming the in.yj .....	19
in.yj field programming options .....	20
Keypad overview .....	21
- Function description .....	22
- Instructions .....	22
- Typical settings .....	24
Troubleshooting .....	25
- in.yj error codes .....	25
- Prr error message: in.yj & in.yj-ce .....	26
- Prr error message: in.yj-re .....	26
- HL error message: in.yj & in.yj-ce .....	27
- HL error message: in.yj-re .....	28
- FLO error message: in.yj & in.yj-ce .....	29
- UPL error message .....	29
- OH error message: in.yj & in.yj-ce .....	30
- OH error message: in.yj-re .....	31
- Pump 1 doesn't work: in.yj & in.yj-ce .....	32
- Pump 1 doesn't work: in.yj-re .....	33
- Nothing seems to work: North American models .....	34
- Nothing seems to work: CE/AUS/NZS models .....	35
- Spa not heating: in.yj & in.yj-ce .....	36
- Keypad doesn't seem to work .....	36
- GFCI/RCD trips .....	37
Specifications .....	38



## Warnings



### WARNINGS:

Before installing or connecting the unit, please read the following.

- \* FOR UNITS FOR USE IN OTHER THAN SINGLE-FAMILY DWELLINGS, A CLEARLY LABELED EMERGENCY SWITCH SHALL BE PROVIDED AS PART OF THE INSTALLATION. THE SWITCH SHALL BE READILY ACCESSIBLE TO THE OCCUPANTS AND SHALL BE INSTALLED AT LEAST 5' (1.52 M) AWAY, ADJACENT TO, AND WITHIN SIGHT OF THE UNIT.
- \* ANY DAMAGED CABLE MUST BE IMMEDIATELY REPLACED BY QUALIFIED PERSONNEL.
- \* TURN POWER OFF BEFORE SERVICING OR MODIFYING ANY CABLE CONNECTIONS IN THIS UNIT.
- \* TO PREVENT ELECTRIC SHOCK HAZARD AND/OR WATER DAMAGE TO THIS CONTROL, ALL UNUSED BUSHING CONDUITS MUST BE PLUGGED WITH THE ATTACHED NIPPLE.
- \* THIS CONTROLLER MUST NOT BE INSTALLED IN PROXIMITY OF HIGHLY FLAMMABLE MATERIALS.
- \* LOW SUPPLY VOLTAGE OR IMPROPER WIRING MAY CAUSE DAMAGE TO THIS CONTROL SYSTEM. READ AND FOLLOW ALL WIRING INSTRUCTIONS WHEN CONNECTING TO POWER SUPPLY.
- \* THIS PACK CONTAINS NO USER SERVICEABLE PARTS. CONTACT AN AUTHORIZED SERVICE CENTER FOR SERVICE.
- \* ALL CONNECTIONS MUST BE MADE BY A QUALIFIED ELECTRICIAN IN ACCORDANCE WITH THE NATIONAL ELECTRICAL CODE AND ANY STATE, PROVINCIAL OR LOCAL ELECTRICAL CODE IN EFFECT AT THE TIME OF THE INSTALLATION.
- \* PRODUCT MUST BE DISPOSED OF SEPARATELY IN ACCORDANCE WITH LOCAL WASTE DISPOSAL LEGISLATION.
- \* THIS APPLIANCE IS NOT INTENDED FOR USE BY PERSONS (INCLUDING CHILDREN) WITH REDUCED PHYSICAL, SENSORY OR MENTAL CAPABILITIES, OR LACK OF EXPERIENCE AND KNOWLEDGE, UNLESS THEY HAVE BEEN GIVEN SUPERVISION OR INSTRUCTION CONCERNING USE OF THE APPLIANCE BY A PERSON RESPONSIBLE FOR THEIR SAFETY.
- \* CHILDREN SHOULD BE SUPERVISED TO ENSURE THAT THEY DO NOT PLAY WITH THE APPLIANCE.
- \* MEANS FOR DISCONNECTION MUST BE INCORPORATED IN THE FIXED WIRING IN ACCORDANCE WITH THE WIRING RULES.
- \* CAUTION: IN ORDER TO AVOID A HAZARD DUE TO INADVERTENT RESETTING OF THE THERMAL CUT-OUT, THIS APPLIANCE MUST NOT BE SUPPLIED THROUGH AN EXTERNAL SWITCHING DEVICE, SUCH AS A TIMER, OR CONNECTED TO A CIRCUIT THAT IS REGULARLY SWITCHED ON AND OFF BY THE UTILITY.
- \* PARTS CONTAINING LIVE PARTS, EXCEPT PARTS SUPPLIED WITH SAFETY EXTRA-LOW VOLTAGE NOT EXCEEDING 12 V, MUST BE INACCESSIBLE TO A PERSON IN THE BATH OR SPA.
- \* PARTS INCORPORATING ELECTRICAL COMPONENTS, EXCEPT REMOTE CONTROL DEVICES, MUST BE LOCATED OR FIXED SO THAT THEY CANNOT FALL INTO THE BATH OR SPA.
- \* PARTS ARE TO BE INSTALLED IN THE CORRECT ZONE AND EQUIPOTENTIAL BONDING CARRIED-OUT IN ACCORDANCE WITH THE WIRING RULES.
- \* CLEARANCE AND MINIMUM DISTANCE BETWEEN THE VARIOUS PARTS OF THE APPLIANCE AND THE SURROUNDING STRUCTURE ARE NOT SPECIFIED AS LONG AS THEY ARE SUFFICIENT SO THAT THE AMBIENT TEMPERATURE AROUND THE CONTROLLER DOES NOT EXCEED 60°C

Aeware®, Gecko®, and their respective logos are Registered Trademarks of Gecko Alliance Group. in.yj™, in.keys™, in.touch™, in.k200™, in.k400™, in.k450™, in.k600™, K-19™, K-35™, K-8™, in.k800™, in.k500™, in.k300™, in.flo™, in.put™, in.seal™, in.link™, in.t.cip™, in.stik™, heat.wav™, Y Series™, and their respective logos are Trademarks of Gecko Alliance Group.

All other product or company names that may be mentioned in this publication are tradenames, trademarks or registered trademarks of their respective owners.



## in.yj

small package, zero compromise

Say hello to the newest member of the Y Series! The in.yj's size makes it easy to install in your small footprint spa, without losing out on functionality and options.

It also offers total heating flexibility. The pack can be bought on its own for use in a heat recovery system (in.yj-re), or bundled with the compact heat.wav-yj heater for efficient heating in any space.

Like all Y Series packs, the in.yj is compatible with our in.k series of keypads. And what's more, the Y Series also takes into account future compatibility, so you can have peace of mind knowing that you can enjoy the Y Series for years to come.



## Features

---

The Y Series systems boast a long list of technical features. Each of them contributes to bringing the most advanced solutions available to Y Series equipped spa owners:



### **in.seal** watertight protection

in.seal provides extra level of protection against water infiltration. Power box are designed to be watertight and no water can be in direct contact with electrical components.



### **in.flo** dry-fire protection

in.flo is an all-electronic dry-fire protection that is built in to the remote heat.wav heater. The in.flo eliminates the burden of adjustments, calibrations and failures associated to usual water flow sensors.



### **in.stik** automated software upload

The in.stik is a pen drive with an in.link connector very similar to a USB memory stick. It connects to the spa pack and contains data to program or configure its system. The system executes the data upload automatically.



### **in.t.cip** water temperature algorithm

in.t.cip is an intelligent water temperature refresh algorithm that calculates optimal time to start pumps and get water temperature readings. In.t.cip continuously readjusts the heater start time.



### **in.touch** you're always in touch with your relaxation

All Y Series packs support the in.touch WiFi interface, allowing you to use your favorite iOS device to communicate with your spa.



### **in.link** ingenious plugs and connectors

The Y Series is only compatible with the low-voltage family of in.link connectors, such as those used by keypads and similar low-voltage accessories.



### **in.put** input terminal block

In.put was designed to ease wire insertion (up to # 6 AWG) and connections. Tighter input connection reduces heat generated for increased component lifetime.



## Overview

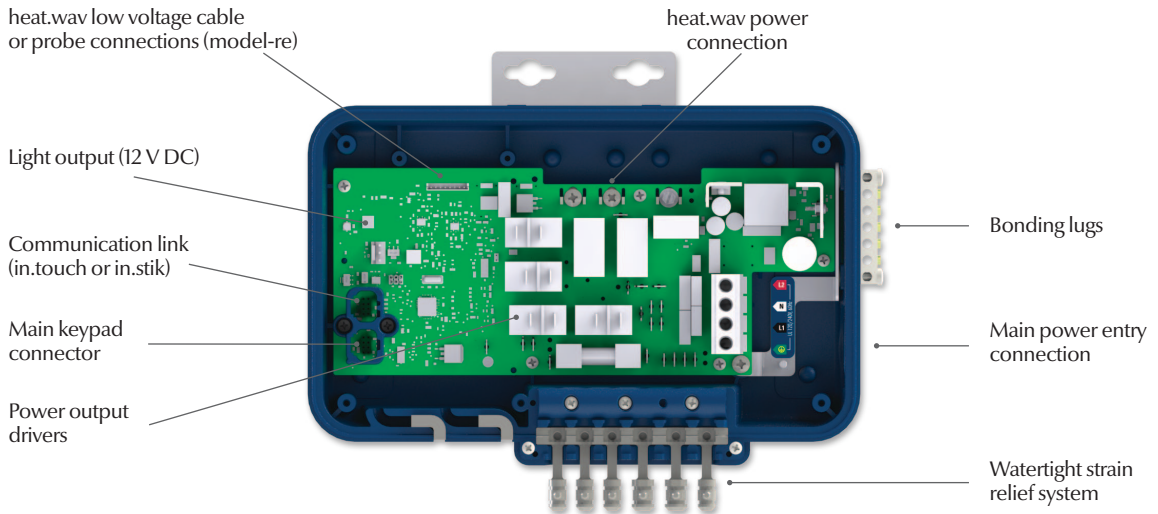

## in.yj dimensions

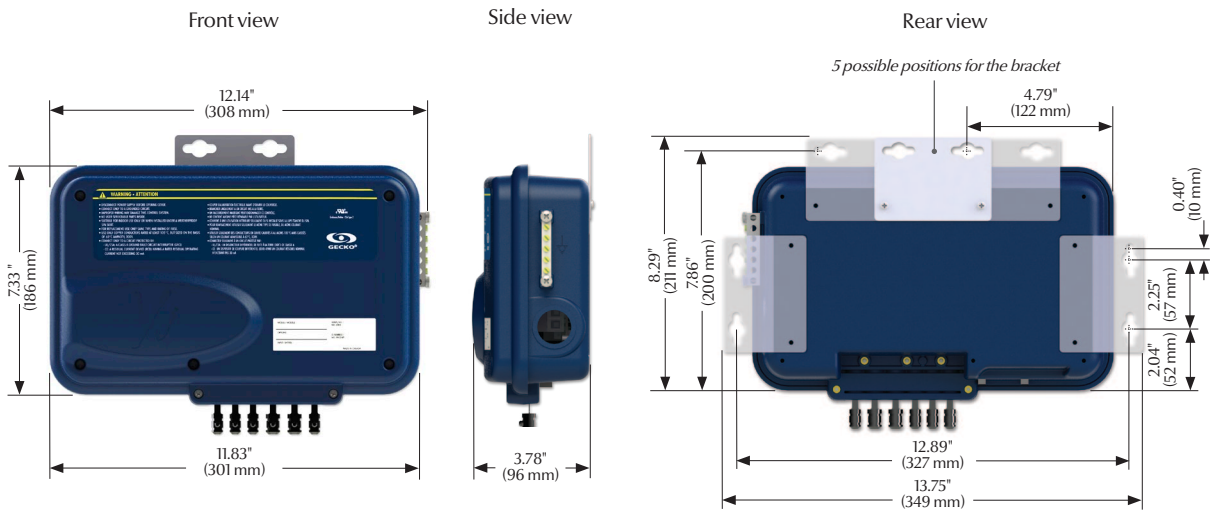

## heat.wav dimensions

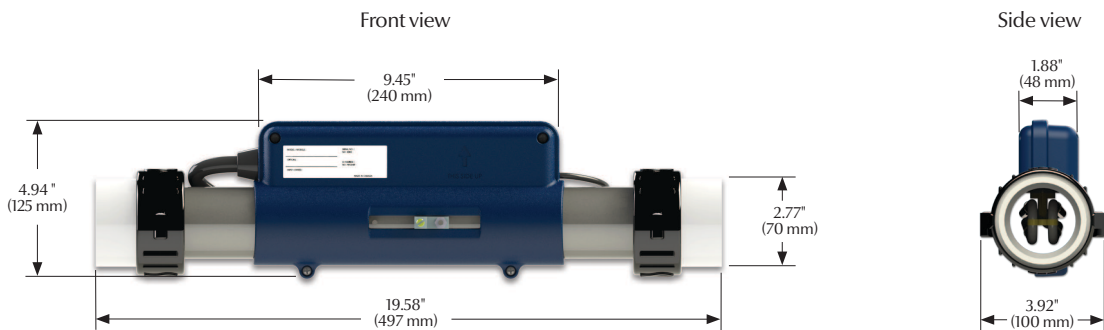

Note: Shown with optional wall mounting brackets (see Installation).



# Installation

## in.yj positioning

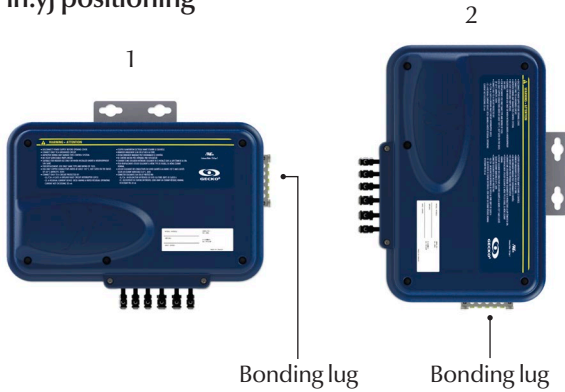

### Warning!

Beware the application of some products commonly used against corrosion (such as WD-40 family products) as they could damage the pack, due to a negative chemical reaction between some industrial oils and its plastic enclosure. Any other materials which may come in contact with the enclosure must be carefully evaluated under end use conditions for compatibility.

To prevent water from getting inside 2 positions are allowed.

Two types of brackets can be used to secure the pack:

## in.yj installation procedure with standard wall mounting bracket(s)



Flat aluminum brackets are designed for back wall mounting. There are 5 possible positions you can use. Multiple brackets can be used if extra support is needed.

Fasten the mounting bracket(s) to the back of the pack with the supplied screws.

*Part number:  
Wall mount bracket kit 100 pcs - 9920-101474  
(with 200 screws to attach to pack)*

Using the brackets, fasten pack to 2" x 4" or 2" x 6" timber wall studs under the spa. We recommend using #10 self threading screws with pan or truss heads and washers 1/2" OD x 1/16" (12 mm OD x 1.5 mm).

*Note: The spa pack must be installed at least 4" (100 mm) above potential flood level. If floor is on ground level, pack should be raised at least 4" (100 mm).*



## Installation

### in.yj installation procedure with wall mounting Z-bracket(s)

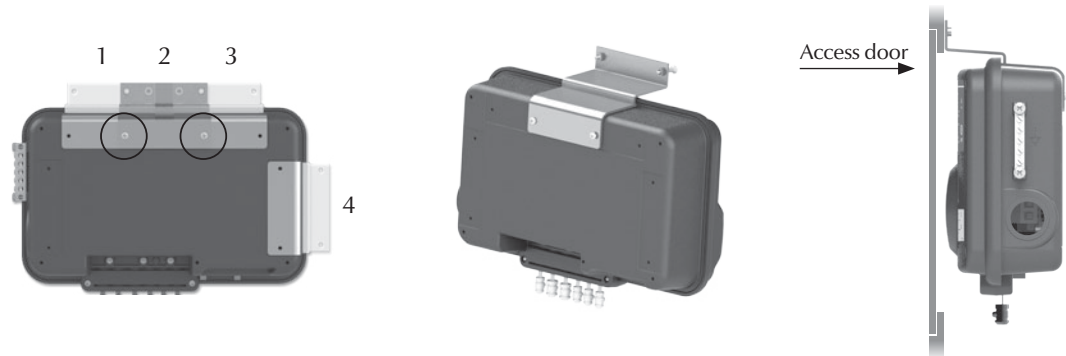

The aluminum Z-bracket is designed for flush-mounting the pack directly on the edge of the access door frame of your spa. It can be mounted to the pack in one of 4 positions for greater flexibility.

Fasten the mounting bracket(s) to the back of the pack with the supplied screws.

*Part number:  
Z-bracket in.yj kit 100 pcs - 9920-101478  
(with 200 screws to attach to pack)*

Depending on your specific needs, you can fasten with two #10-24 screws of your choice.

*Note: The spa pack must be installed at least 4" (100 mm) above potential flood level. If floor is on ground level, pack should be raised at least 4" (100 mm).*

### heat.wav installation (not applicable on in.yj-re models)



The heat.wav heating element must be installed in the return circuit of the main pump (pressure side).

### Keypad installation

See the techbook for your specific keypad model for installation details and drilling template.





## Connections

### Preparation

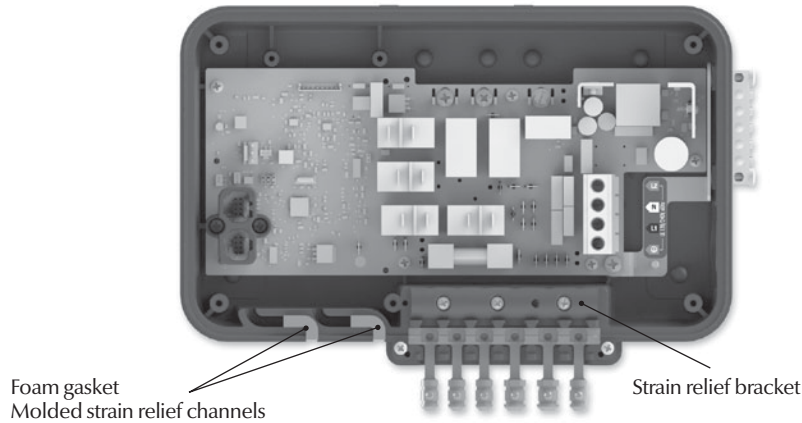

Remove the cover screws from the front of the pack with a Phillips screw driver.

Remove and put aside the strain relief bracket and the foam gasket located in the molded strain relief channels.

### Connecting the main keypad and the light socket cable

*Note: always shut power down before connecting an accessory to the pack.*

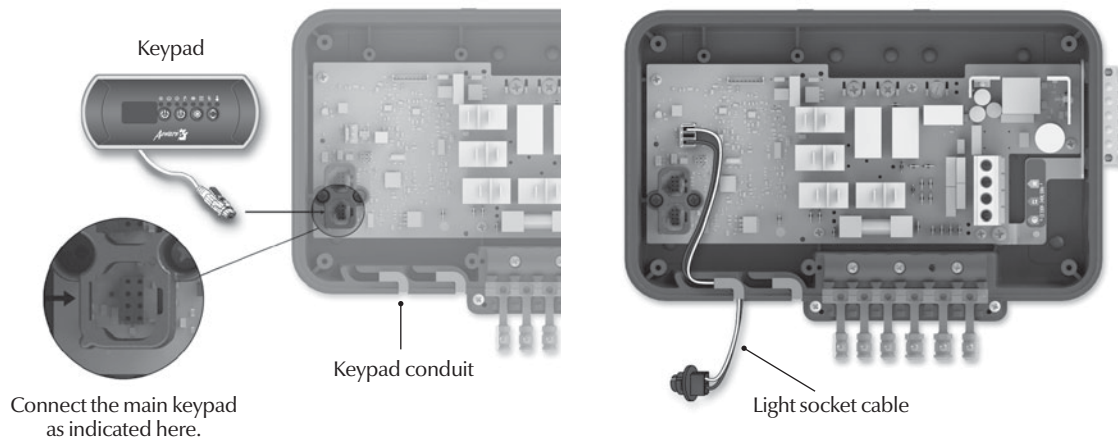

To connect the keypad, insert the in.link connector into the appropriate keypad connector (as illustrated).

To connect the light socket cable, insert the MTA connector into the 12 V DC light output connector P33 (as illustrated).

*Part number:  
Light socket cable - 9920-400489*

Route the low voltage cables through the molded strain relief channels on the bottom of the spa pack.



# Connections

## Connecting the heat.wav (not applicable on in.yj-re models)

The in.yj should be paired with a high performance heat.wav heater.

Part numbers:

2 kW heat.wav - 0613-421002

3 kW heat.wav - 0613-421003

4 kW heat.wav - 0613-421001

heat.wav specification summary:

- in.flo integrated dry-fire protection
- Supports 120 V or 240 V
- Protected by external breaker (not fused)\*
- Incoloy® heater element

*\*Note: CE/AUS/NZS models are 230-240 V only, and are fuse protected.*

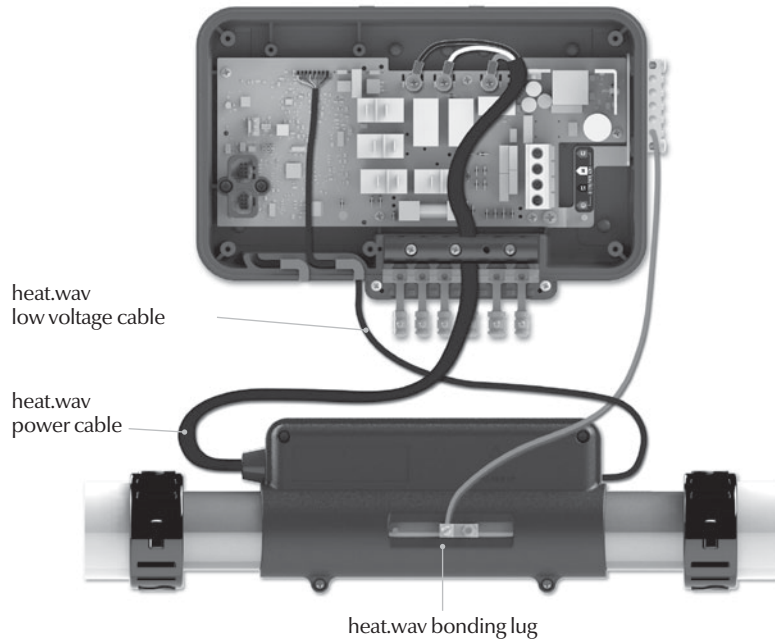

*Note: always shut power down before connecting an accessory to the pack.*

Connect a solid copper conductor (not smaller than 8 AWG) between the bonding lugs on the side of the spa pack and the bonding lug at the front of the heat.wav. The bonding conductor should be routed close to the contour of the equipment to reduce the risk of damage during servicing.

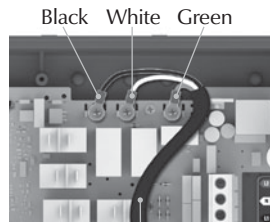

heat.wav power cable

Connect the colored wires  
black = P3  
white = P4  
green = P5

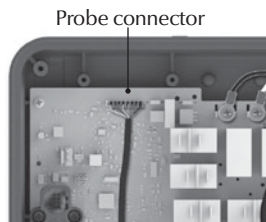

To connect the heat.wav low voltage cable, insert the JST into the probe connector (P1).

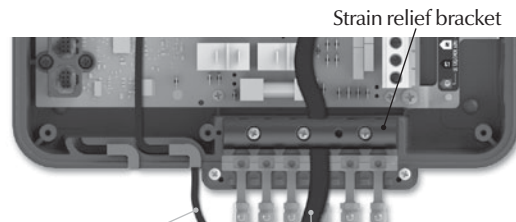

Route the low voltage cable through one of the molded strain relief channels on the bottom of the spa pack.

Remove the small rubber stopper. Route the power cable through one of the openings for 12-3 cable size (as illustrated on page 14).



# Connections

## Connecting high voltage accessories: North American model in.yj

Wires to connect high voltage accessories must have 0.25" quick-connect terminals.

These tabs require high-voltage accessories to have straight, non-insulated, female quick-connect terminals for all connections, including ground. Depending on where the connections are made on the in.yj pack PCB, 120 V and 240 V accessories are supported. Refer to the following tables for correct connections. Note that all female terminals must be correctly and completely seated on the PCB tab for proper current ratings.

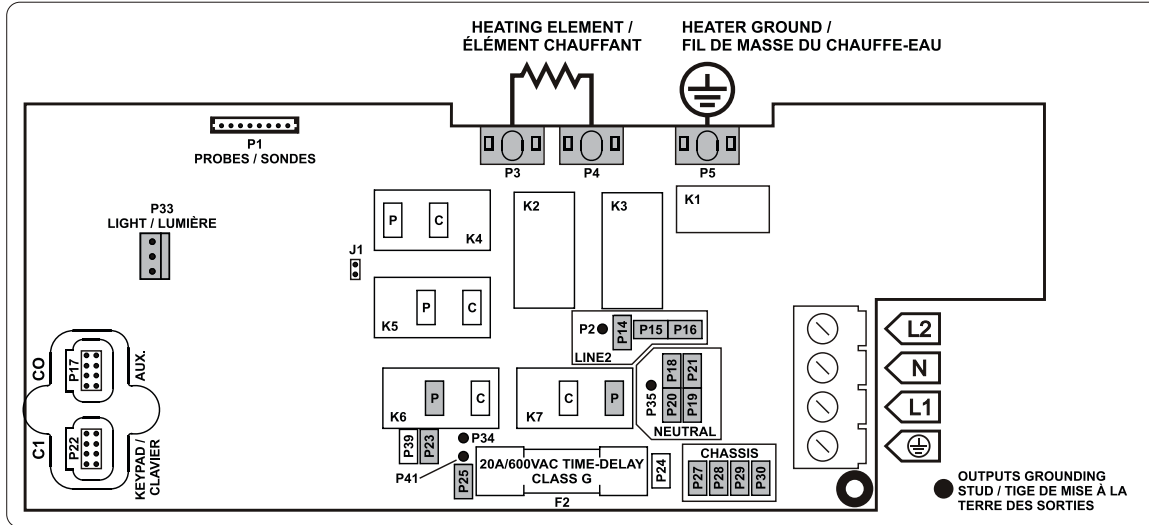

Direct output Voltage	120 V	240 V	Pump 1 Voltage	120 V	240 V	Ozone (Working with pump 1 low speed) Voltage	120 V	240 V	Light (12 V DC, 500mA)	
Green / ground	P27	P27	Green / ground	P28	P28	Green / ground	P29	P29	Switch	P33
Black / line	P25	P25	Black / low speed	K6-P	K6-P	Black / line	P23	P23		
White / common	P18	P14	Red / high-speed	K7-P	K7-P	White / common	P21	P16		
			White / common	P19	P15					

Heat.wav-yj	
Green / ground	P5
Black / line	P3
White / common	P4

Make sure all accessories are linked to the bonding lug connector located on the side of the spa pack.

This table shows typical connections. OEMs may have a different connection scheme.



## Connections

### Connecting high voltage accessories: European, Australian, New Zealand model in.yj-ce

These tabs require high-voltage accessories to have straight, non-insulated, female quick-connect terminals for all connections, including ground. Refer to the following tables for correct connections. Note that all female terminals must be correctly and completely seated on the PCB tab for proper current ratings.

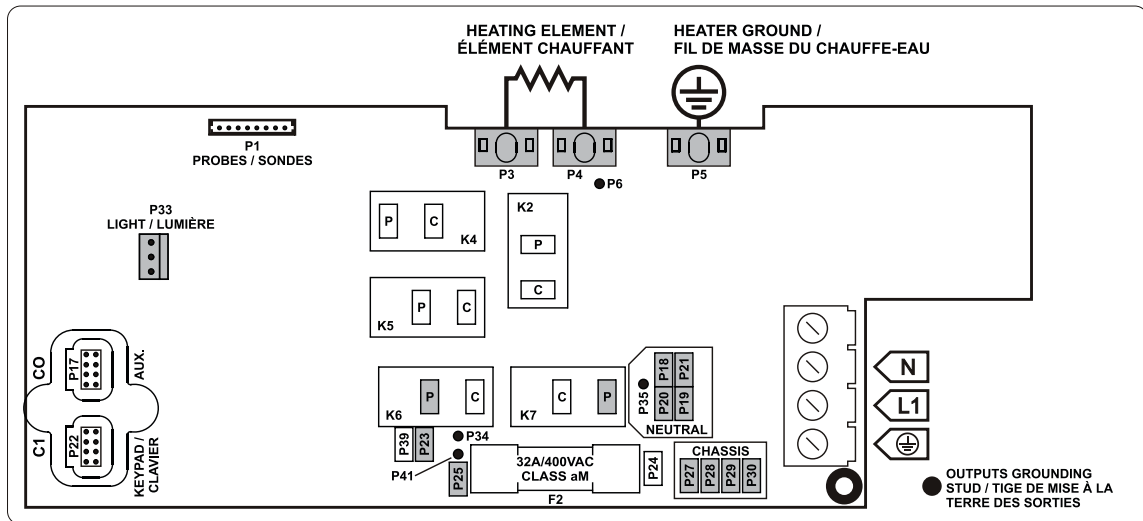

Direct output	230 V	Pump 1	230 V	Ozone	230 V	Light (12 V DC, 500 mA)	
Ground	P27	Ground	P28	Ground	P29	Switch	P33
Line	P25	Low speed	K6-P	Line	P23		
Common	P18	High-speed	K7-P	Common	P21		
		Common	P19				

Heat.wav-yj	
Green / ground	P5
Black / line	P3
White / common	P4

Make sure all accessories are linked to the bonding lug connector located on the side of the spa pack.

This table shows typical connections. OEMs may have a different connection scheme.



## Connections

---

Connecting the probe assembly on heat recovery model in.yj-re

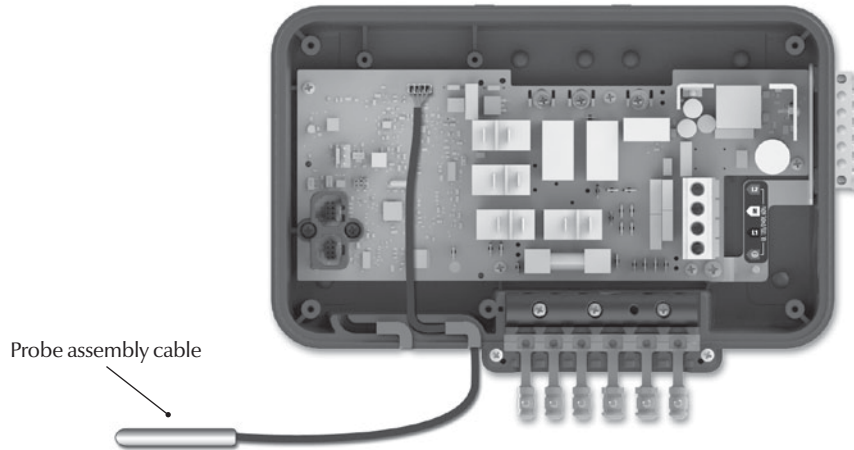

The probe assembly must be installed in the spa water in an area where water is not stagnant in order to optimize the temperature regulation.

To connect the probe assembly cable, insert the JST into the probe connector (P40).

Route the probe assembly cable through one of the molded strain relief channels on the bottom of the spa pack.

*Part number:  
Probe assembly - 9920-401397*



# Connections

## Connecting high voltage accessories: North American heat recovery model in.yj-re

These tabs require high-voltage accessories to have straight, non-insulated, female quick-connect terminals for all connections, including ground. Refer to the following tables for correct connections. Note that all female terminals must be correctly and completely seated on the PCB tab for proper current ratings.

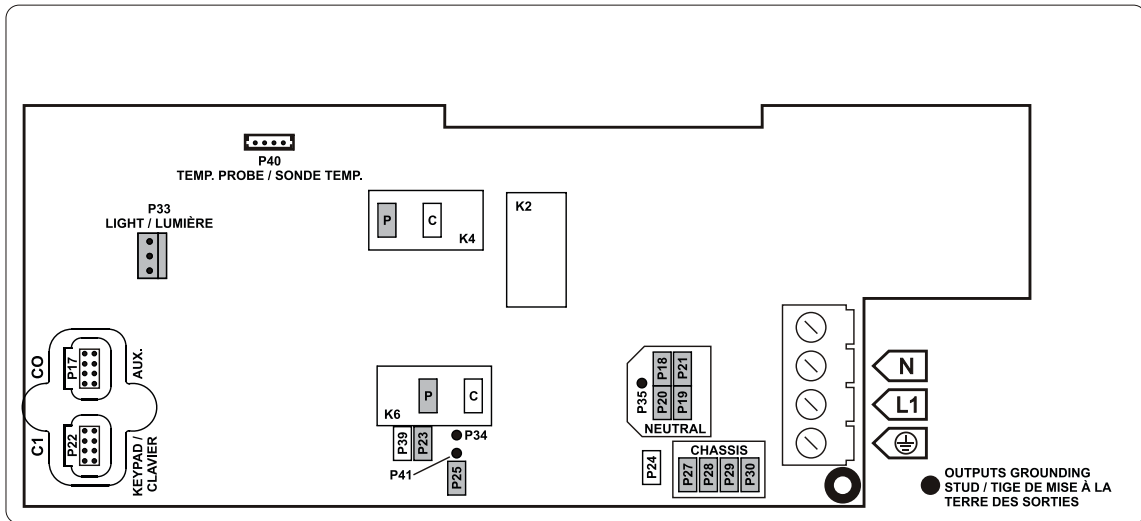

Direct output Voltage	120 V	Pump 1 Voltage	120 V	Ozonator Voltage	120 V	Light (12 V DC, 500mA)	
Green / ground	P27	Green / ground	P28	Green / ground	P29	Switch	P33
Black / line	P25	Black / low speed	K6-P	Black / line	P23		
White / common	P18	Red / high-speed	K4-P	White / common	P21		
		White / common	P19				

Make sure all accessories are linked to the bonding lug connector located on the side of the spa pack.

This table shows typical connections. OEMs may have a different connection scheme.



## Connections

### Completing the installation

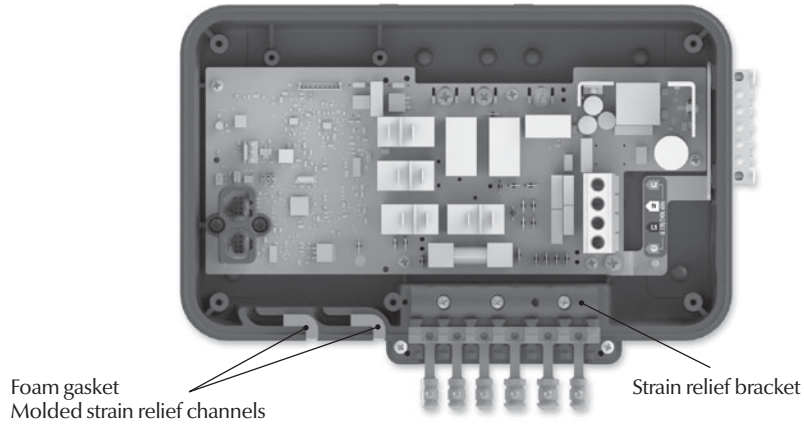

Once all low voltage cables are routed through the molded strain relief on the bottom of the spa pack, fill the remaining space with the foam gasket supplied.

Once all high voltage accessories cables are routed through one of the openings provided for this purpose at the bottom of the spa pack, you can reinstall the strain relief bracket.

Replace the cover. Do not over tighten cover screws (torque to 8 in. lb max (0.9N.m.)

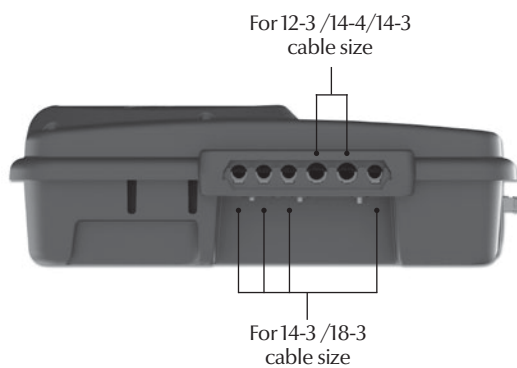

Output cable opening size



## Electrical wiring

### Electrical wiring: all models

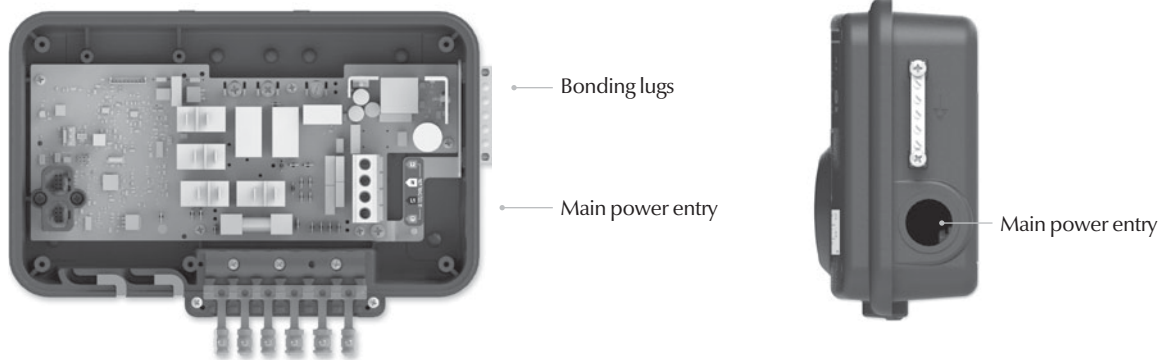

#### Warning!

Disconnect power before starting electrical work.  
Wiring must be completed by a qualified electrician and must be done in accordance with the local electrical code.

To complete the electrical connections of the in.yj remove the spa pack over with a Phillips screwdriver.

Remove 5 1/2" (142 mm) of cable insulation.

Strip away 1/2" (15 mm) of insulation from each wire.

Pull the cable through the cutout of the box and secure it with a 3/4" NPT strain relief\* (hole diameter 1.09" {27.6 mm}). Ensure that the NPT strain relief clamps around the outer sheath of the cable.

\*For CE/AUS/NZ use an IEC certified plastic bushing that will maintain the IPX5 rating.

### Electrical wiring: North American models

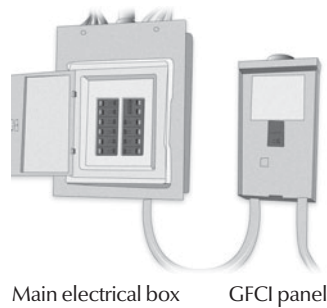

#### Warning!

For units for use in other than single-family dwellings, a clearly labeled emergency switch shall be provided as part of the installation. The switch shall be readily accessible to the occupants and shall be installed at least 5' (1.52 m) away, adjacent to, and within sight of the unit.

-----  
This product must always be connected to a circuit protected by a ground fault interrupter.

-----  
Proper wiring of the electrical service box, GFCI and in.yj terminal block is essential!

-----  
Check your electrical code for local regulations. Only copper wire should be used, never aluminum.



#### Disposal of the product

The appliance (or the product) must be disposed of separately in accordance with the local waste disposal legislation in force.





# Electrical wiring

## Before November 2014

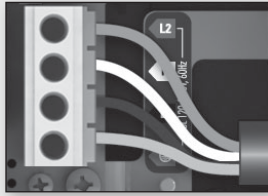

240 V (4 wires)

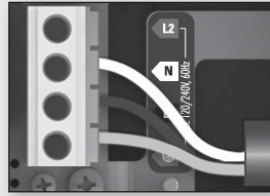

120 V (3 wires)

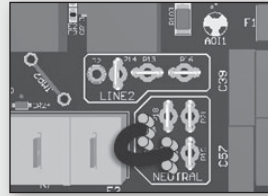

240 V (4 wires) Default

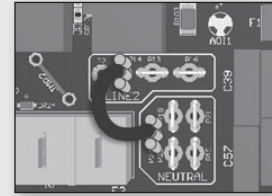

120 V (3 wires)

Insert each wire into the appropriate socket of the main entry terminal block according to the color code indicated on the sticker. Use a flat screwdriver to tighten the screws on the terminal.

The heater is factory configured at 240 V (4 kW). To convert it to 120 V (1 kW) configuration, move the wire jumper from P35-P20 (240 V) to P35 - P14 (120 V)

## After November 2014

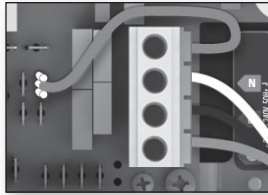

120 V (3 wires)

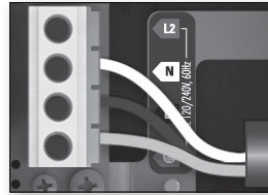

240 V (4 wires)

DO NOT REMOVE THE BROWN WIRE. Insert each wire into the appropriate socket of the main entry terminal block according to the color code indicated on the sticker. Use a flat screwdriver to tighten the screws on the terminal.

Remove the brown wire and insert each wire into the appropriate socket of the main entry terminal block according to the color code indicated on the sticker. Use a flat screwdriver to tighten the screws on the terminal.

After making sure wires are securely connected, push them back into the box and replace the cover. Do not over tighten cover screws (torque to 8 in.lb max {0.9 N.m.}). Connect the bonding conductor to the bonding lug on the side of the spa pack (a grounded electrode conductor should be used to connect the equipment grounding conductors).

## Electrical wiring diagram

Refer to wiring diagram in the enclosure box lid for more information.

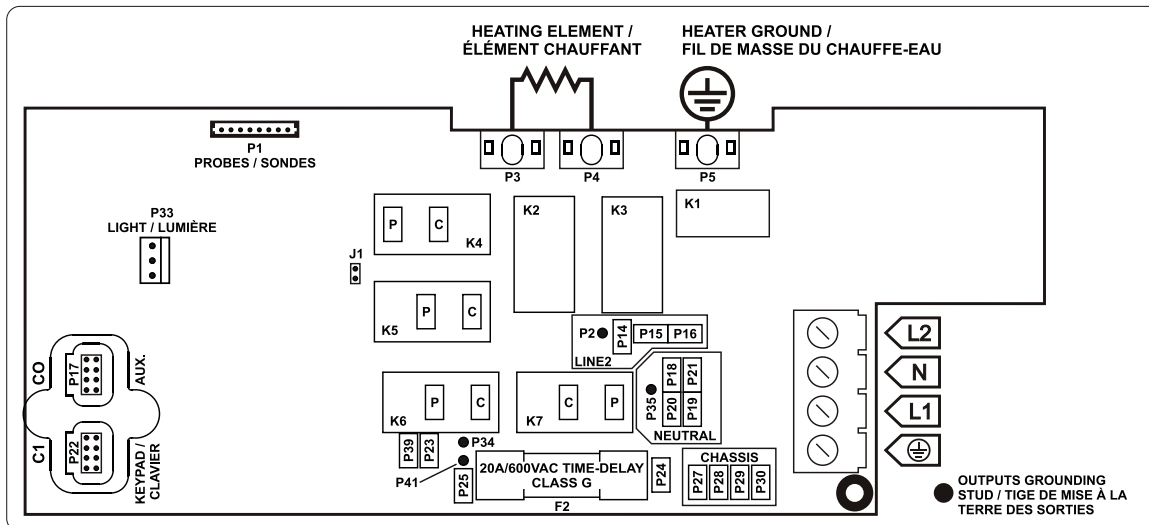



## Electrical wiring

### Electrical wiring: CE/AUS/NZS models



#### Warning!

in.yj.ce models must always be connected to a circuit protected by a Residual-Current Device (RCD) having a rated operating residual-current not exceeding 30 mA.

Correct wiring of the electrical service box, RCD, and pack terminal block is essential!

Check your electrical code for local regulations. Only copper wire should be used, never aluminum.

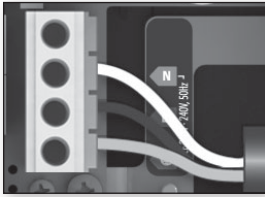

230 V (3 wires)

Insert each wire into the appropriate socket of the main entry terminal block according to the color code indicated on the sticker. Use a flat screwdriver to tighten the screws on the terminal.

After making sure wires are securely connected, push them back into the box and replace the cover. Do not over-tighten cover screws (torque to 8 in.lb max {0.9 N.m.}).

Connect the bonding conductor to the bonding lug on the side of the spa pack (a grounded electrode conductor should be used to connect the equipment grounding conductors).

### Electrical wiring diagram

Refer to wiring diagram in the enclosure box lid for more information.

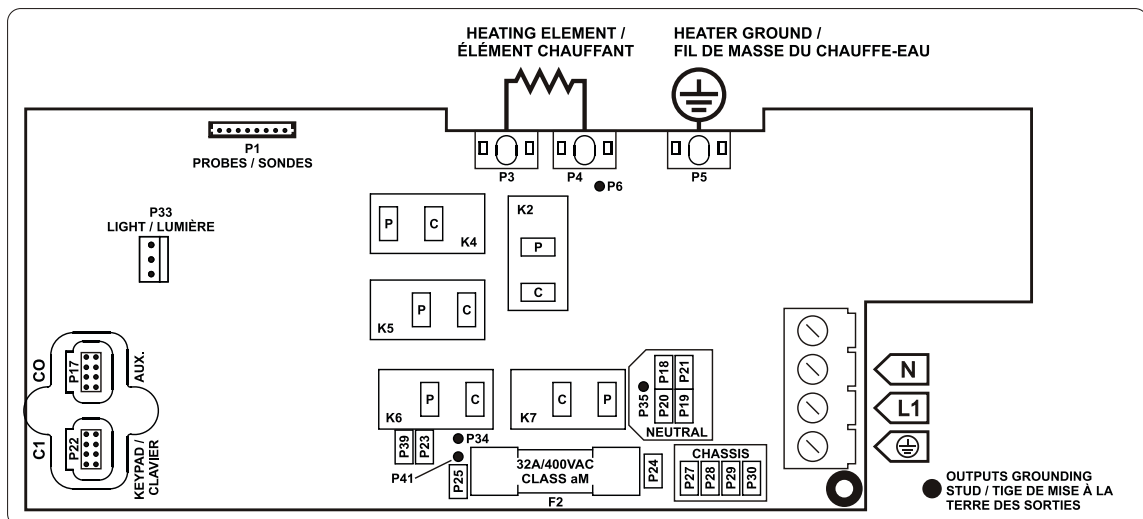



## Power-up & breaker setting

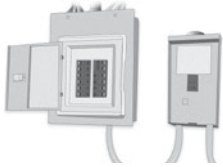

### IMPORTANT! Read before starting

A minimum flow rate of 18 GPM is required. Make sure that all valves are open in the spa plumbing and that you have good water flow circulation from the primary pump into the heater.

Turn on the breaker.

### in.flo dry-fire protection

At power up, the in.flo detector performs a flow check through the following process:

Pump 1 or circulation pump starts for 2 minutes.

The display will show " \_ \_ " during the check flow process. After 2 minutes the system validates proper water flow.

In case of failure, the system tries again. The water temperature is shown on the keypad display. Once the water has reached the set point value plus 0.8°F the heater is turned off.

### Boot up display sequence (Each parameter is displayed for 2 seconds)



Lamp test

All the segments and LEDs light up.



Software number

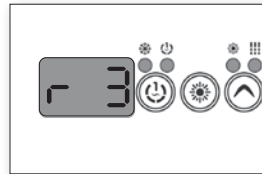

Software revision

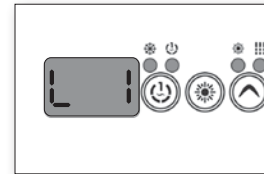

Low-level selection

Low-level selected from low-level menu.

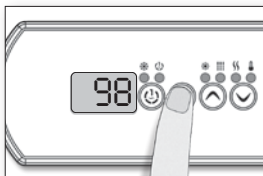

It's important to specify the current rating of the GFCI/RCD used to ensure safe and efficient current management (and reduce nuisance GFCI/RCD trippings).

Press and hold the **Prog** button until you access the breaker setting menu (programming menu will appear first).

*Note: if the keypad in use does not have the Prog button, use the Light button instead.*



The values displayed by the system correspond to 0.8 of the maximum amperage capacity of the GFCI/RCD.

Use the **Up/Down** buttons to select the desired value.

The value can typically be modified from 10 to 32 A.

Press the **Prog** button to set breaker rating.



This table shows typical settings of b for different GFCI/RCD ratings. Select the one that matches your breaker.

GFCI/RCD	b
30 A	24 A
20 A	16 A
16 A	12.8 A
15 A	12 A

*Note: Every OEM has its own preset configurations.*



## Programming the in.yj

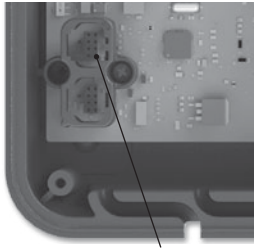

communications port

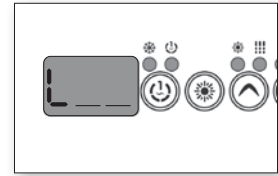
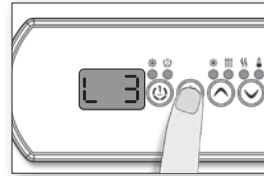

### Programming the in.yj using the in.stik

Follow these simple steps to upload new pre-determined low-level program configurations into the spa pack.

Shut electrical power off.

Remove the cover to access the low-voltage in.link connectors inside, connect the in.stik to the communications port (see figure), and then re-apply power to pack.

At power-up the spa pack will upload all the different configurations from the in.stik memory. The unit will then enter the low-level configuration menu.

The keypad display will show Lxx where "xx" represents the previous configuration number registered in the system.

Use the Up/Down key to choose the new desired low-level configuration number.

Press the **Prog** key to confirm the selected configuration.

If the **Prog** key is not pressed within 25 seconds, the unit will exit this menu without changing any settings.

*Note: If the keypad in use does not have the Prog key, use Light key instead.*

If, when the system powers up, your keypad display shows the following message:

"L \_\_", it means that all low-level configurations have been downloaded, but no configuration number has been chosen.

*Note: When programming is finished, do not forget to turn power off, remove the in.stik, and re-install the pack's cover.*

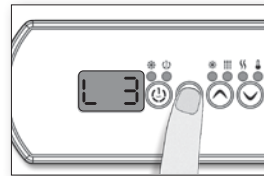
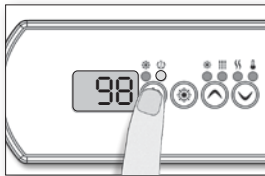

### Programming the in.yj using a keypad

Although every in.yj spa pack is factory set, in certain cases when servicing or replacing a new unit in the field, it may be necessary to set a new pre-determined low-level program configuration into the spa pack.

Follow these simple steps to re-enter the low-level programming menu using the keypad:

Press and hold the **Pump 1** key for 30 seconds.

The keypad display will show Lxx where "xx" represents the previous configuration number registered in the system.

Use the Up/Down key to choose the new desired low-level configuration number.

Press the **Prog** key to confirm the selected configuration.

If the **Prog** key is not pressed within 25 seconds, the unit will exit this menu without changing any settings.

If, when the system powers up, your keypad display shows the following message:

"L \_\_", it means that all low-level configurations have been downloaded, but no configuration number has been chosen.

*Note: If the keypad in use does not have the Prog key, use the Light key instead.*

Please refer to the Quick Start Card for your model to set the proper low level and connector location. Contact your OEM for specific configurations.

Model	Quick Start Card Number
in.yj-2-RE	9919-101241
in.yj-2	9919-101242
in.yj-2-CE	9919-101243



## in.yj field programming options

In the event that none of the predetermined low-level program configurations built in the unit's system suit your spa equipment assembly, it's possible to custom configure the system by manually entering key parameter settings (see Table 1).

To access this menu, press and hold the **Prog** (or **Light**) key for 30 seconds. Use the **Up/Down** keys to choose setting. Press the **Prog** key (or **Light** key) to go to the next parameter.

Parameters available will depend on your model.

Field programming is only available on selected keypads.

**Table 1**

Parameter	Display	Options	Description
Output 1	1. _ _	--,1H,1L,2H,2L,3H,3L,4H,4L,P5,BL,CP,O3,L2,H, ON	Accessory connected to relay Output 1
Output 2	2. _ _	--,1H,1L,2H,2L,3H,3L,4H,4L,P5,BL,CP,O3,L2,H, ON	Accessory connected to relay Output 2
Output 3	3. _ _	--,1H,1L,2H,2L,3H,3L,4H,4L,P5,BL,CP,O3,L2,H, ON	Accessory connected to relay Output 3
Output D	d. _ _	--,CP	Accessory connected to the Direct Output
Heater	H. _ _	--,H	Accessory connected to the heater relay
CP usage	[C] _ _	CP Standard = 0 CP Always On = 1	Usage of the circulation pump
Ozone usage	[O] _ _	Ozone with filtration = 0 Ozone Always On = 1	Usage of the ozone generator
Ozone Pump	[O] P _ _	Circulation pump = 0 Pump #1 = 1	Pump associated with the ozone generator
Ozone Type	[O] _ _	Standard (UV) = 0 Timed (Corona) = 1	Type of ozone generator
Heater Pump	[H] P _ _	Circulation pump = 0 Pump #1 = 1	Pump associated with the Heater
Filter Config	[F] L _ _	Purge only = 0 With Circ. Pump = 1 With Pump 1, Low speed = 2 With Pump 1, low speed, 2 durations = 3	Filter cycle configuration
Temp. Units	[U] n. _ _	°F = 0 °C = 1	Temperature units used on display
Clock Format	[C] L _ _	No time display = 0 AM/PM format = 1 24H format = 2	Clock display format
Cool down	[C] _ _ _	30 to 240 seconds	Cool down of the heating element in seconds
Output 1 current	1. _ _	0 to 15 amperes	Current draw of Output 1 accessory
Output 2 current	2. _ _	0 to 15 amperes	Current draw of Output 2 accessory
Output 3 current	3. _ _	0 to 15 amperes	Current draw of Output 3 accessory
Output D current	d. _ _	0 to 5 amperes	Current draw of Direct output 1 accessory
Output H current	H. _ _	0 to 17 amperes	Current draw of the heater
CE/AUS/NZS Configuration	[C] E _ _	UL = 0 CE/AUS/NZS = 1	CE/AUS/NZS or UL setup
Input current	b. _ _	10 to 32A Single Phase (UL and CE)	Available household current



---

## Keypad overview



The following instructions are generic and provide a quick overview of the main keypad functions. Please refer to your own QRC for specific functions.

The in.yj spa pack is compatible with the following keypads: in.k300, in.k200, in.k400, in.k450, in.k500, in.k600 (streamlined), K-4, K-19, K-35, K-8 (with in.link connector) and in.k800 (color display).



# Keypad overview

## Function description

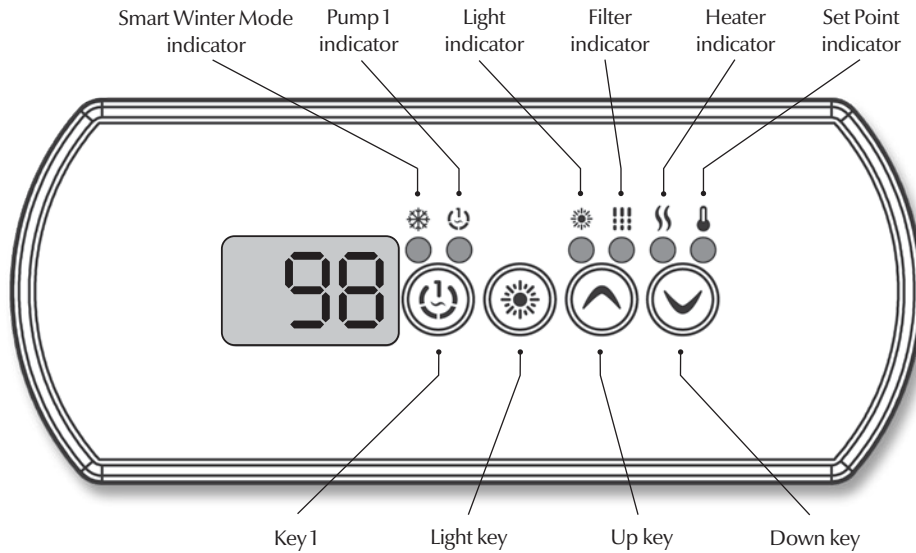

## Instructions

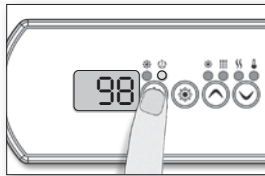

### Key 1

Press **Key 1** to turn pump 1 on at low speed. Press a second time to turn pump to high speed (with a dual-speed pump). A third time turns the pump off.

A built-in timer automatically turns pump off after a predetermined period of time, unless it has been manually deactivated.

The Pump 1 indicator lights up when pump 1 is on. With dual-speed pump, the indicator will flash when pump 1 is on at low speed.

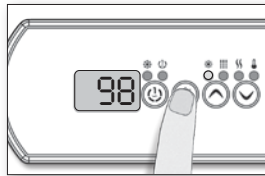

### Light key

Press the **Light** key to turn light on. Press the **Light** key a second time to turn light off.

A built-in timer automatically turns light off after a predetermined period of time, unless it has been manually deactivated.

The Light indicator lights up when light is on.

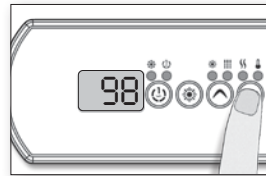

### Up/Down key

Use the **Up/Down** keys to set desired water temperature. The temperature setting will be displayed for 5 seconds to confirm your new selection.

When the Set Point indicator is lit the display shows the desired temperature, NOT the current water temperature!

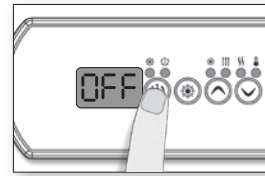

### Off Mode

This mode allows you to stop all outputs for 30 minutes to perform a quick spa maintenance.

Press and hold **Key 1** for 5 sec. to activate the Off mode. Press **Key 1** to reactivate the system before the expiration of the 30 minute delay.

While the Off mode is engaged, the display will toggle between OFF and the water temperature.



## Keypad overview

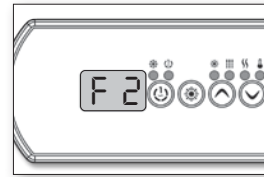
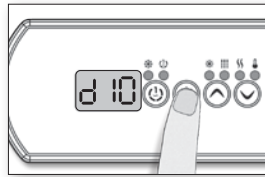

### Programming the system

Depending on system configuration the system performs either purge cycles or filter cycles.

### Filter cycles

To program the filter cycles, you must enter the duration and frequency. During a filter cycle, pumps & blower run at high speed for one minute to purge the plumbing. Pump 1 or CP then runs at low speed for the remainder of the cycle.

### Setting filter cycle duration

Press and hold the **Prog** or **Light** key until the display shows d xx, with "xx" representing the duration in hours.

Use the **Up/Down** keys to change setting.

0 = no filtration

24 = continuous filtration

*Note: it's not recommended to set this to "0".*

### Filter cycle frequency

Press the **Prog** or **Light** key again. The display will show Fx, with "x" representing the number of filter cycles per day (up to 4).

Use the **Up/Down** keys to change the setting.

When the desired setting is displayed, Press the **Light** key to confirm. A filter cycle will start immediately.

The Filter indicator lights up when a filter cycle is on.

### Purge cycles

To program the purge cycles, you must select

the frequency. During a purge cycle, all pumps and the blower run for one minute.

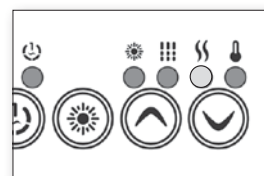
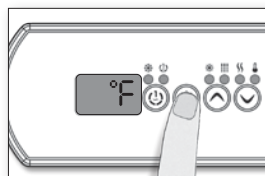

### Purge cycle frequency

Press and hold the **Light** key until the display shows Fx, with "x" representing the number of purge cycles per day (up to 4).

Use the **Up/Down** keys to change setting.

When the desired setting is displayed, Press the **Light** key to confirm. A purge cycle will start immediately.

The Filter indicator lights up when a purge cycle is on.

### Setting the temperature display units

Press the **Light** key again.

The display will show either °F or °C.

Use the **Up/Down** keys to change units.

Press the **Light** key a last time to go back to normal mode.

°F = Fahrenheit

°C = Celsius

### Water temperature regulation

In a regulation cycle, the system first generates water flow through the heater housing and the plumbing, in order to ensure accurate water temperature readings as well as avoiding heater activation in dry conditions.

The system verifies periodically that all parameters are within normal range.

If the readings received from the system are not valid, blanks (- - -) will be displayed until normal readings have been successfully recorded.

After verifying pump activation and taking a water temperature reading if required, the system automatically turns the heater on to reach and maintain water temperature at Set Point. The Heater indicator lights up when the heater is on. It flashes when there is a request for more heat but the heater has not yet started.





# Keypad overview

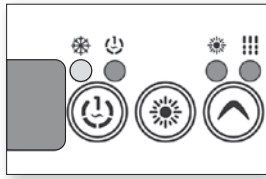

## Smart Winter Mode

Our Smart Winter Mode protects your system from the cold by turning pumps on several times a day to prevent water from freezing in pipes. The Smart Winter Mode indicator lights up when the Smart Winter Mode is on.

## Cool down

After heating the spa water to the desired Set Point, the heater is turned off, but its associated pump (Pump 1 low-speed or CP) remains on for a certain amount of time to ensure adequate cooling of the heating element, prolonging its life.

The Heater icon flashes during this time.

## Typical settings

Adjustable Regulating Set Point:	59°F (15°C) to 104°F (40°C)
Factory Default Set Point:	Typical 95°F (35°C) / Max 100°F (38°C)
Filter Cycle Duration:	0 to 24 hrs / Factory set at 2 hrs
Filter Cycle Frequency:	1 to 4 times a day / Factory set at 2
Filter Cycle Start:	00:00 to 23:59 / Factory set at 12:00
Pump Runtime:	Factory set at 20 min.
Light Timeout:	Factory set at 120 min.

## Keypads available for the in.yj:



K-19



K-35



in.k200 (LED display, 4 keys, 8 light indicators)



in.k600 (streamlined)



in.k300

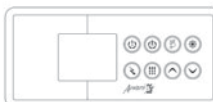

K-4



K-8



in.k450 (LCD display, 6 keys, 10 function icons)



in.k800



in.k500



## Troubleshooting

### in.yj error codes

Error codes indicate a failure condition or a problem which needs to be corrected to ensure proper functioning of the system. Both the error code and the water temperature are alternatively displayed.

All errors codes will be displayed on the keypad display.

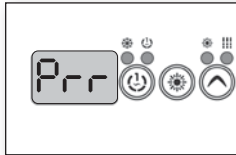

#### Prr

The Prr error message indicates a problem with the regulation probe. The system is constantly verifying if temperature probe reading is within normal limits.



#### HL

Water temperature at the heater has reached 119°F.

**Do not enter spa water!**



#### FLO

The system did not detect any water flow while the main pump was running.



#### UPL

No low-level configuration software has been downloaded into the system.



#### AOH

Temperature inside the spa skirt is too high, causing the internal temperature in the spa pack to go above normal limits.



#### OH

Water temperature in the spa has reached 108°F.

**Do not enter spa water!**



## Troubleshooting

### Prr error message: in.yj & in.yj-ce



Regulation probe issue

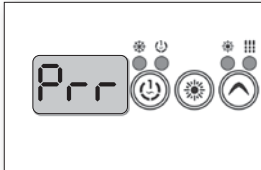

Probe connector (P1)

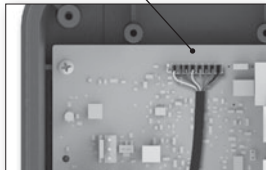

- Verify that the heat.wav low voltage cable is properly connected to the probe connector (P1).
- Replace heat.wav if problem persists.
- Replace spa pack, if problem persists.

### Prr error message: in.yj-re



Regulation probe issue

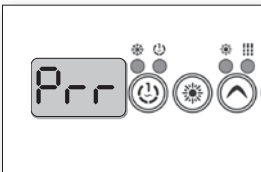

Probe connector (P40)

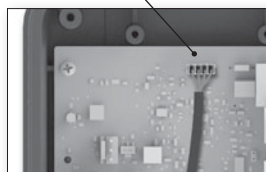

- Verify that the probe assembly cable is properly connected to the probe connector (P40).
- Replace the probe assembly if problem persists.
- Replace spa pack, if problem persists.



## Troubleshooting

### HL error message: in.yj & in.yj-ce



The system has shut down because the temperature at the heater has reached 119°F (48°C).



Probe connector (P1)

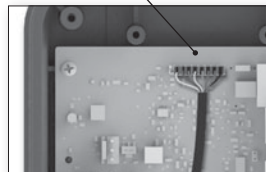

- Measure the temperature with a DIGITAL thermometer and compare its reading with temperature on the display.

#### If reading is below 119°F:

- Carefully check if heater barrel feels hot. If it's hot, check that nothing is obstructing water flow (closed valves or dirty filter).
- If it is not hot, check that the heat.wav low voltage cable is connected to the probe connector at P1.
- Shut power off and power the spa up again to reset the system.
- If HL error persists, replace heat.wav.
- If HL error persists, replace spa pack.

#### If reading is 119°F or higher and does not match temperature on the display:

- Verify that the heat.wav low voltage cable is properly connected to probe connector P1.
- If cable is connected, replace heat.wav
- Shut power off and power the spa up again to reset the system.
- If HL error persists replace spa pack.

#### If reading is 119°F or higher and weather is very hot:

- Remove spa cover (even during the night).
- Start blower if spa is equipped with one.
- Wait until spa cools down (add cold water if necessary).
- Shut power off and power the spa up again to reset the system.

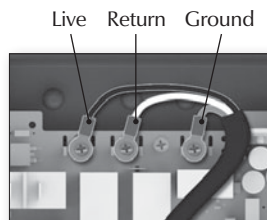
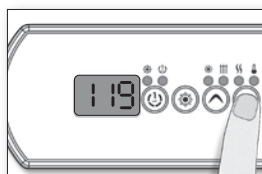

#### If reading is 119°F or higher and hot weather is not an issue:

- Verify that the heat.wav low voltage cable is properly connected to probe connector P1.
- Lower Set Point below current water temperature.  
The Heater indicator should disappear from keypad display.
- With a voltmeter, read voltage between the live and ground heater terminals located in the spa pack.
- If you read 120 V or 240 V, replace spa pack.
- If you do not read 120 V or 240 V, pump may be overheating water during filter cycle.
- Shorten filter cycle duration.
- Shut power off and power the spa up again.



## Troubleshooting

### HL error message: in.yj-re



The system has shut down because the temperature at the probe assembly location has reached 119°F (48°C).

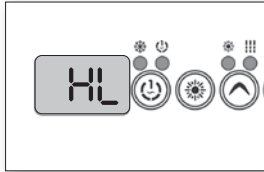

Probe connector (P40)

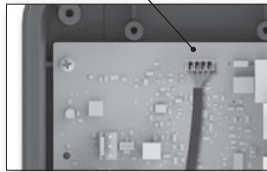

- Measure the temperature with a DIGITAL thermometer and compare its reading with temperature on the display.

#### **If reading is below 119°F:**

- Check if the probe assembly is located in the piping. If it is, make sure that nothing is obstructing water flow (closed valves or dirty filter).
- If it is not, verify that the probe assembly cable is properly connected to probe connector P40.
- Shut power off and power the spa up again to reset the system.
- If HL error persists, replace the probe assembly.
- If HL error persists, replace spa pack.

#### **If reading is 119°F or higher and does not match temperature on the display:**

- Verify that the probe assembly cable is properly connected to probe connector P40.
- If cable is connected, replace probe assembly.
- Shut power off and power the spa up again to reset the system.
- If HL error persists replace spa pack.

#### **If reading is 119°F or higher and weather is very hot:**

- Remove spa cover (even during the night).
- Wait until spa cools down (add cold water if necessary).
- Shut power off and power the spa up again to reset the system.

#### **If reading is 119°F or higher and hot weather is not an issue:**

- Verify that the probe assembly cable is properly connected to probe connector P40.
- Lower Set Point below current water temperature. The Heater indicator should disappear from the keypad display.
- Turn off all pumps. If a pump is still running, replace spa pack.
- Shut power off and power the spa up again to reset the system.
- If HL error persists, replace the probe assembly.
- If HL error persists, replace spa pack.

## Troubleshooting

### FLO error message: in.yj & in.yj-ce

**FLO**

The system did not detect any water flow while the primary pump was running.

Make sure that the low-level programming has been properly set, with or without circulation pump (depending on your system configuration).



Probe connector (P1)

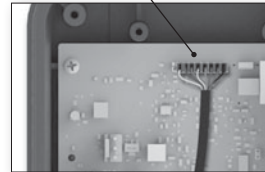

- Make sure water valves are open and that water level is high enough.
- Check and remove anything obstructing the filter.
- Make sure there is adequate flow (minimum 18 GPM)
- Make sure that no airlocks are trapped in the unit's plumbing (pumps may make strange noises). If airlocks are formed, start the pump and slowly loosen one of the union nuts to release the air trapped in the plumbing. Tighten the nut again after you are done.
- Make sure that the pump associated to the heater (primary pump) is running.
- Make sure that the heat.wav low voltage cable is properly connected to the probe connector (P1).
- If problem persists replace heat.wav.
- If the problem is not solved replace the spa pack.

### UPL error message

**UPL**

No low-level configuration software in system!



- New low-level configuration software needs to be downloaded into the spa system; without it the system will not be operable.
- Contact our toll free line for technical support (1-800-784-3256).

*Note: this line is dedicated to assist authorized service technicians and dealers only.*



## Troubleshooting

OH error message: in.yj & in.yj-ce



Water temperature in the spa has reached 108°F



- Measure water temperature with a DIGITAL thermometer and compare its reading with the temperature on the display.

**If temperature reading is different:**

- Shut power off and power the spa up again to reset the system.
- If OH error persists, replace heat.wav.
- If OH persists, replace spa pack.

**If temperature on display is correct (above 108°F) and weather is hot:**

- Remove spa cover and let spa cool down.
- Add cold water and lower filter cycles.
- If problem persists replace spa pack.

**If temperature on display is correct (above 108°F) and hot weather is not a factor:**

- Lower Set Point below current water temperature. The Heater indicator should disappear from the keypad display.
- Turn off all pumps. If a pump is still running, replace spa pack.
- If not, the pump may be overheating the water during filter cycle. Shorten filter cycle duration.



## Troubleshooting

OH error message: in.yj-re



- Measure water temperature with a DIGITAL thermometer and compare its reading with the temperature on the display.

### If temperature reading is different:

- Shut power off and power the spa up again to reset the system.
- If OH error persists, replace probe assembly.
- If OH persists, replace spa pack.

### If temperature on display is correct (above 108°F) and weather is hot:

- Remove spa cover and let spa cool down.
- Add cold water and lower filter cycles.
- If problem persists replace spa pack.

### If temperature on display is correct (above 108°F) and hot weather is not a factor:

- Lower Set Point below current water temperature. The Heater indicator should disappear from the keypad display.
- Turn off all pumps. If a pump is still running, replace spa pack.
- If not, the pump may be overheating the water during filter cycle. Shorten filter cycle duration.





# Troubleshooting

## Pump 1 doesn't work: in.yj & in.yj-ce

If Pump 1 is not working,

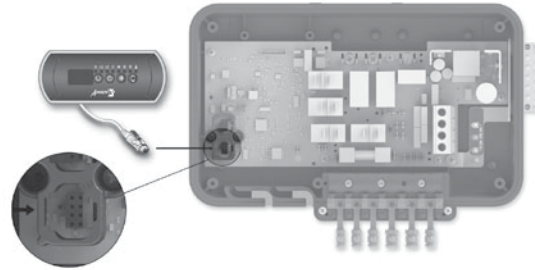
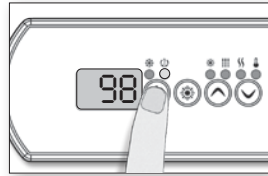

- Check for an error message on keypad display. If there is one, refer to the specific section indicated by the error message.
- Verify low-level programming configuration.

- Check if the Pump 1 indicator appears on keypad display when you press **Key 1**.

### If the Pump 1 indicator does not appear:

- Use a spare keypad to verify if keypad is defective.
- If it is, replace keypad.
- If not, replace spa pack.

### If Pump 1 indicator appears:

- Verify if pump works in either speed.

Pump 1 fuse (F2)

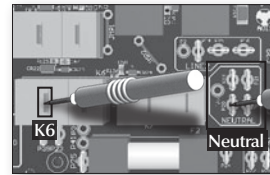
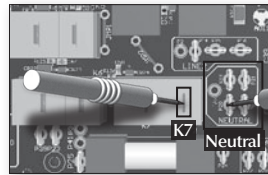
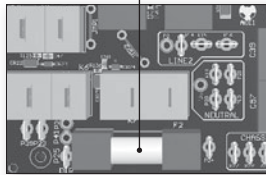

### If Pump 1 does not work in either speed:

- Replace appropriate Pump 1 fuse.
- If replacing the fuse is not effective or if Pump 1 works in only one speed, take a voltage reading on the corresponding connector.

- Turn Pump 1 to high speed and take voltage reading between: K7 & neutral  
Your reading should be:  
120 V for North American models  
230 V for CE/AUS/NZS models

- Turn Pump 1 to low speed and take voltage reading between: K6 & neutral  
Your reading should be:  
120 V for North American models  
230 V for CE/AUS/NZS models

If voltage is as it should be, check wiring and plugs, and replace as necessary. Replace Pump 1 if needed.

If voltage is not correct, replace spa pack.

# Troubleshooting

## Pump 1 doesn't work: in.yj-re

If Pump 1 is not working,

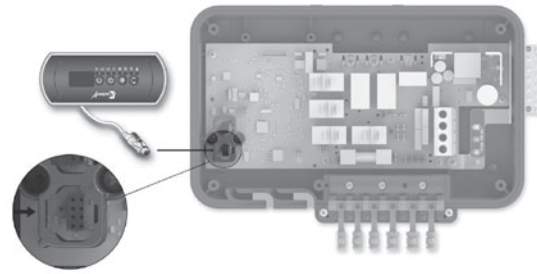
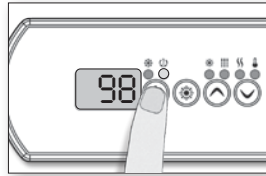

- Check for an error message on keypad display. If there is one, refer to the specific section indicated by the error message.
- Verify low-level programming configuration.

- Check if the Pump 1 indicator appears on keypad display when you press **Key 1**.

### If the Pump 1 indicator does not appear:

- Use a spare keypad to verify if keypad is defective.
- If it is, replace keypad.
- If not, replace spa pack.

### If Pump 1 indicator appears:

- Verify if pump works in either speed.

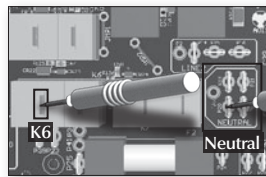
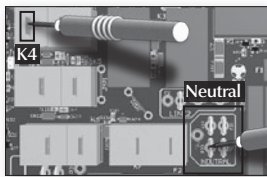

- Turn Pump 1 to high speed and take voltage reading between: K4 & neutral

Your reading should be:

120 V for North American models

230 V for CE/AUS/NZS models

- Turn Pump 1 to low speed and take voltage reading between: K6 & neutral

Your reading should be:

120 V for North American models

230 V for CE/AUS/NZS models

If voltage is as it should be, check wiring and plugs, and replace as necessary. Replace Pump 1 if needed.

If voltage is not correct, replace spa pack.



## Troubleshooting

### Nothing seems to work: North American models

Verify that all screws are properly tightened on the terminal block. Turn power off and make sure that all cables hold firmly in the terminal block if you pull on them. Once done, turn power back on.

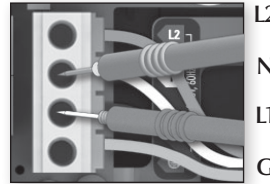
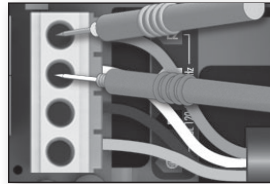
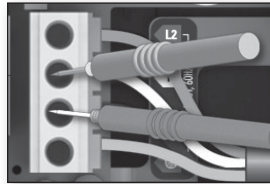
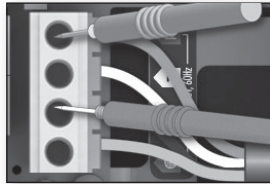

#### For 240 V systems

- On the terminal block, measure voltage between line 1 and line 2.

You should get 240 V.

- Measure voltage between line 1 and neutral.

You should get 120 V.

- Measure voltage between line 2 and neutral.

You should get 120 V.

#### For 120 V systems

- Measure voltage between line 1 and neutral.

You should get 120 V.

If you do not get good readings, this indicates an electrical wiring problem.

Call an electrician!

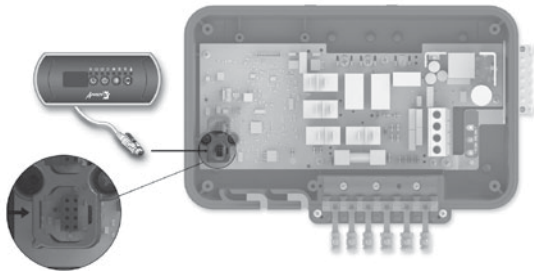

- Check that keypad is connected to spa pack correctly.



## Troubleshooting

### Nothing seems to work: CE/AUS/NZS models

Verify that all screws are properly tightened on the terminal block. Turn power off and make sure that all cables hold firmly in the terminal block if you pull on them. Once done, turn power back on.

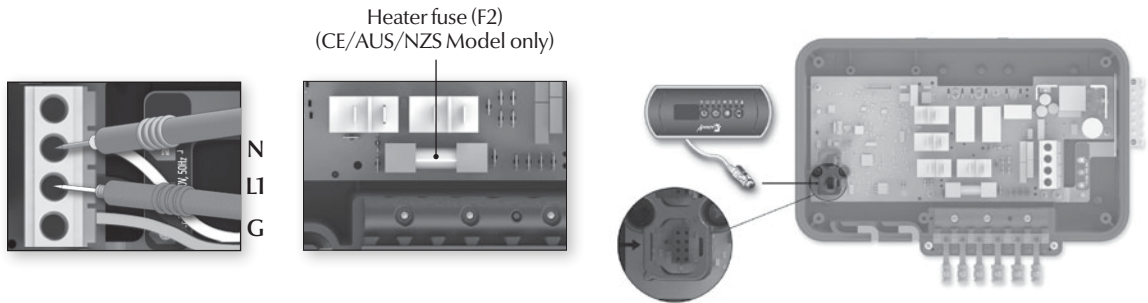

- On the terminal block, measure voltage between line 1 and neutral.

You should get 230 V.

**If you get good readings but no response from any accessories (heat.wav, pumps) replace heater fuse (F2).**

**If you do not get good readings, this indicates an electrical wiring problem.**

**Call an electrician!**

- Check that keypad is connected to spa pack correctly.



## Troubleshooting

### Spa not heating: in.yj & in.yj-ce

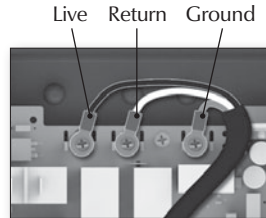
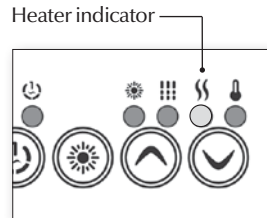
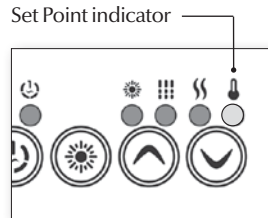

- Check for an error message on keypad display. If there is one, refer to specific section indicated by the error message.
- If there is no error message, try to raise water temperature by increasing the Set Point 2°F higher than actual water temperature. Press Up key to increase Set Point.

- Check if Heater indicator appears on keypad display.  
  
The Heater indicator will be on when heater is on. It will flash if more heat has been requested, but heater has not started yet.

#### If Heater indicator lights up on the display:

- Take voltage reading between the heater live and return terminals.

Your reading should be:

240 V: for spa packs configured in 240 V

120 V: for spa packs configured in 120 V

If voltage reading is not as it should be, replace spa pack.

If voltage reading is as it should be, verify that the heat.wav power cable is properly connected to the terminal screws in the spa pack. If they are, replace heat.wav.

If Heater indicator does not light up on the display, measure water temperature and compare with temperature on display:

- If less than 2°F difference, there is no problem.
- If greater than 2°F difference, replace the heat.wav.

If problem persists, replace the spa pack.

### Keypad doesn't seem to work

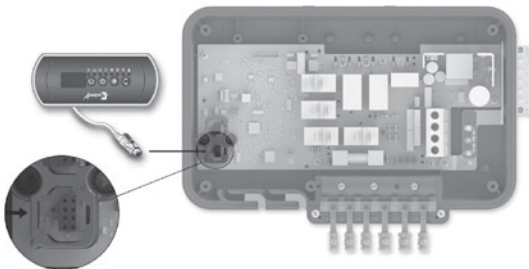

If a keypad doesn't work:

- Verify keypad connections and try spare keypad.
- Replace keypad if problem is corrected.
- Replace pack if problem persists.

## Troubleshooting

### GFCI/RCD trips

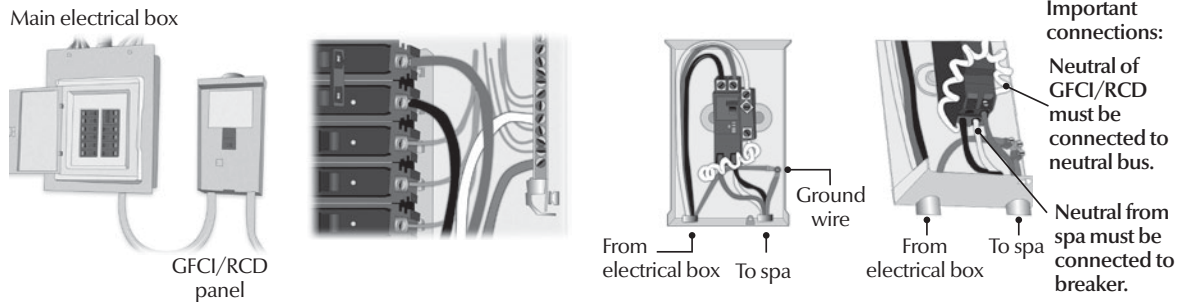

#### Warning!

**Total current output cannot exceed total current input rating!**

There are different GFCI/RCD models used on the market. See manufacturer's instructions that come with the GFCI/RCD for specific information. Note that all illustrations are examples only.

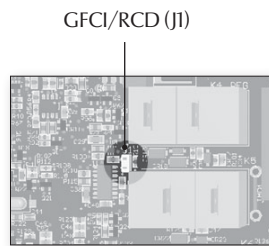

The Y Series packs are equipped with a GFCI/RCD tripper circuit in case an HL error occurs.

- Find the GFCI/RCD tripper circuit (J1) on the board located near relay K4 and remove the jumper.
- Reset the GFCI/RCD and see if an error occurs. If HL appears, follow the HL error troubleshooting chart (in the Troubleshooting section).
- If no error occurs, re-install the jumper.

*Note: If the GFCI/RCD trips only when jumper (J1) is installed, replace the spa pack.*

The GFCI/RCD trips and the jumper (J1) is not installed, the error doesn't come from the GFCI/RCD tripper circuit.

- Verify that the GFCI/RCD circuit is properly connected.
- If it's not, reconnect it.
- Verify the spa pack wiring (make sure that the neutral and the ground have not been inverted).

**If the GFCI/RCD is properly connected but still tripping,**

- Unplug all outputs from the spa pack (pumps, blower, heater, ozonator etc).
- If it doesn't trip while all outputs are unplugged, reconnect one output at a time until the GFCI/RCD trips again.
- Replace defective component.

*Note: Incorrect GFCI/RCD wiring may lead to a condition where the GFCI/RCD may NOT trip when it should, causing electrical shock hazard. All electrical installations should be done by qualified personnel only.*



## Specifications

### Environmental ratings:

Operating temperature:	32°F (0°C) to 140°F (60°C)
Storage temperature:	-13°F (-25°C) to 185°F (85°C)
Humidity:	Up to 85% RH, non condensing
Level of waterproofing:	IPx5 for TUV (CE/AUS/NZS) & CSA Enclosure #2

### Mechanical:

#### in.yj

Weight:	3.1 lb (1.41 kg)
Dimensions (W x H x D):	12.08" x 7.38" x 3.74" (307 x 187 x 95 mm)

#### heat.wav

Weight:	4.65 lb (2.1 kg)
Dimensions (W x H x D):	19.58" x 4.94" x 3.92" (497 x 125 x 100 mm)

### in.yj UL/CSA electrical specifications\*1

Input rating:	120/240 V nominal (+5/-10%), 60 Hz nominal (+1.5 / -1.0 Hz) (2 lines required with neutral) 32 A Max,
or:	120 V nominal only (+5/-10%), (single line with neutral) 16 A Max

#### Heat.wav rating:

Voltage:	120 or 240 V, 60Hz
Wattage:	4 kW at 240 V, 1 kW at 120 V
Flow rate:	Minimum of 18 GPM (68 LPM) is required

Device *2	Voltage *3	Maximum current
Pump 1 (2-spd)	120 or 240 V	15 FLA/60 LRA (inrush)
O3*4	120 or 240 V	3 FLA/6 A
Direct out 1	120 or 240 V	10 A (always on)
Light output	12 Vdc	0.5 AMP (6W Light bulb)

UL 1563 Sixth Ed. (2012)

UL File: E182156

CSA No. 22.2 - 218.1-M89. (2013)



\*1 Certain current limits may apply. Please talk to your customer service representative for more information.

\*2 Total of Pump 1, O3 and Direct out should not exceed 16 A for UL/CSA version.

\*3 The output voltage is selectable according to input supply voltage provided.

\*4 The ozonator is connected in parallel with the Pump 1 low speed, therefore they cannot be controlled independently.



## Specifications

### in.yj TUV (CE/AUS/NZA) electrical specifications<sup>\*1</sup>

**Input rating:** 220 - 240 V nominal with neutral (+5/-10%)  
 50/60 Hz nominal (+1.5 / -1.0 Hz)  
 Monophase system 32 A max

**Heat.wav rating:**

**Voltage:** 220 - 240 V, 50/60 Hz

**Wattage:** 4 kW at 220 - 240 V

**Flow rate:** Minimum of 18 GPM (68 LPM) is required

Device <sup>*2</sup>	Voltage <sup>*3</sup>	Maximum current
Pump 1 (2-spnd)	220 - 240 V	15 FLA/60 LRA (inrush)
O3 <sup>*4</sup>	220 - 240 V	3 FLA/6 A
Direct out 1	220 - 240 V	10 A (always on)
Light output	12 Vdc	0.5 AMP (6W Light bulb)

EN/IEC 60335 - 2 - 60: /A12:2010 - EN/IEC 60335 - 1: /A15:2011

EN55014-1

EN55014-2

EN61000-3-2

EN61000-3-3



<sup>\*1</sup> Certain current limits may apply. Please talk to your customer service representative for more information.

<sup>\*2</sup> Total of Pump 1, O3, heater, and Direct out should not exceed 32 A for TUV (CE/AUS/NZA) version.

<sup>\*3</sup> The output voltage for the TUV (CE/AUS/NZA) version will reflect the input voltage, typically 230 V.

<sup>\*4</sup> The ozonator is connected in parallel with the Pump 1 low speed, therefore they cannot be controlled independently.



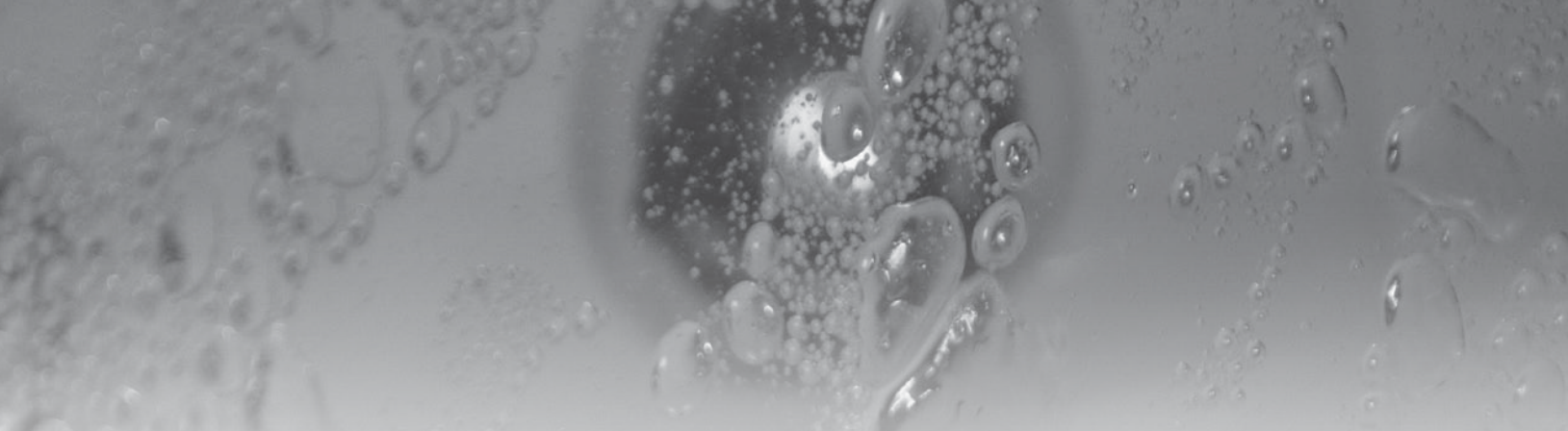

9919-101235-B  
Rev. 10-2014

© Groupe Gecko Alliance Inc., 2014  
All trademarks or registered trademarks  
are the property of their respective owners.

**Gecko Alliance**  
450 des Canetons, Quebec City (Qc), G2E 5W6 Canada, 1.800.78.GECKO  
[www.geckoalliance.com](http://www.geckoalliance.com)

Printed in Canada